

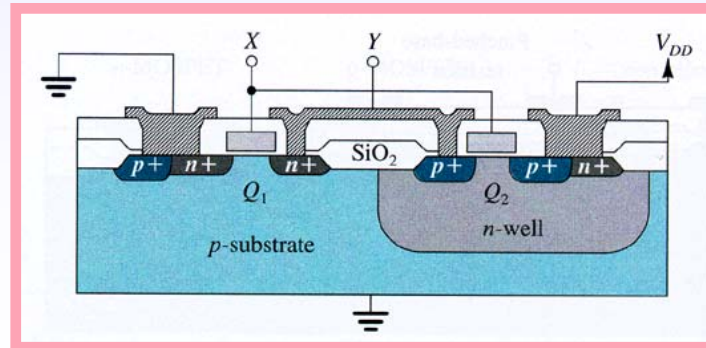

Processos Avançados de Microeletrônica

Prof. Dr. Antonio Carlos Seabra
acseabra@lsi.usp.br

Projeto e Fabricação de CIs

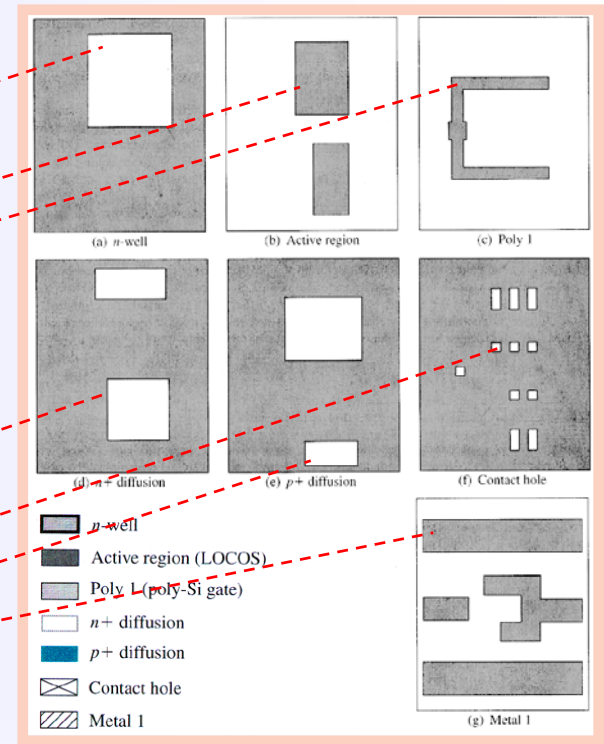
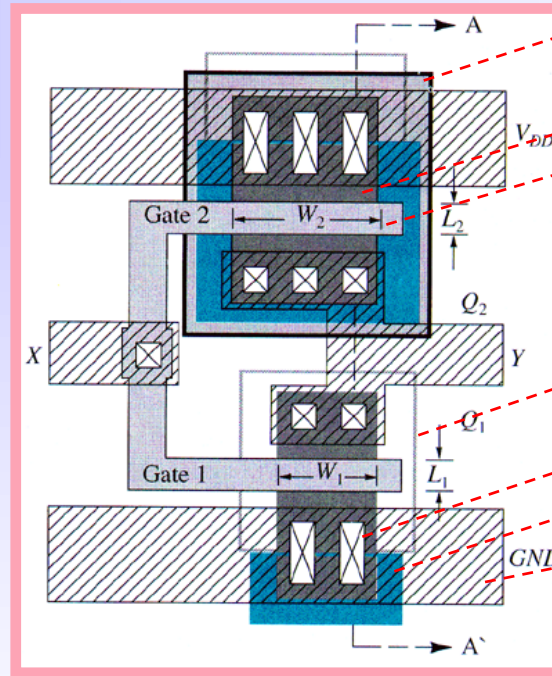
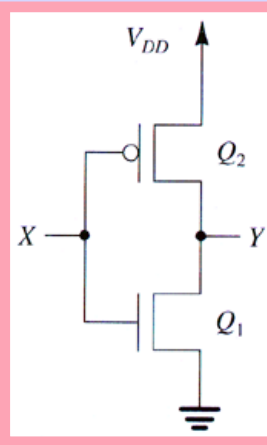
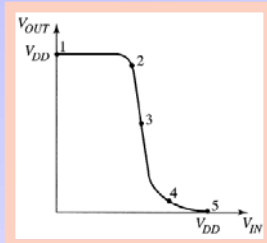
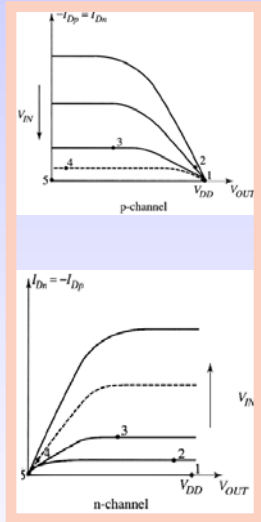

As Etapas de Fabricação de CIs

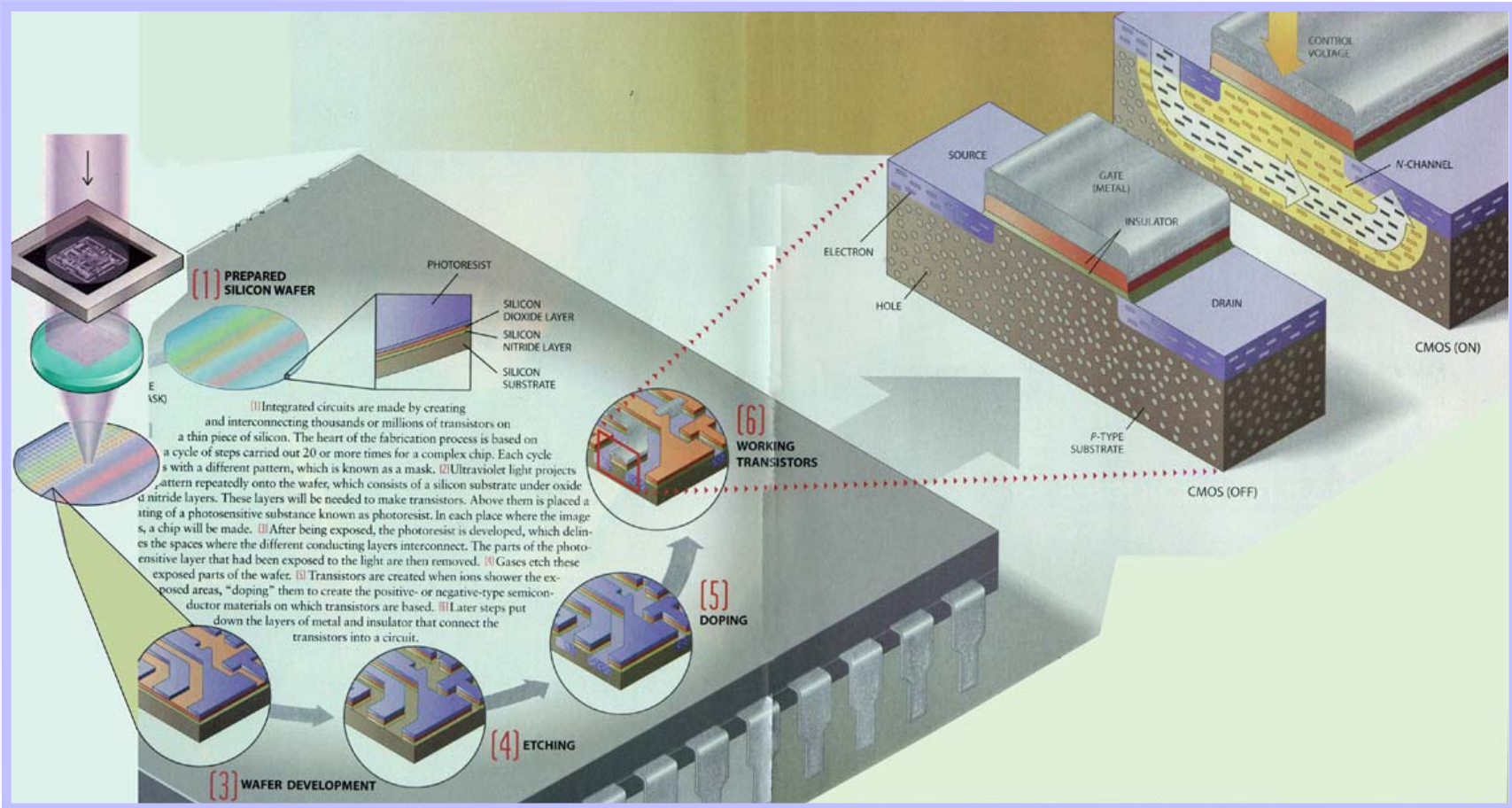

Projeto e Fabricação de CIs

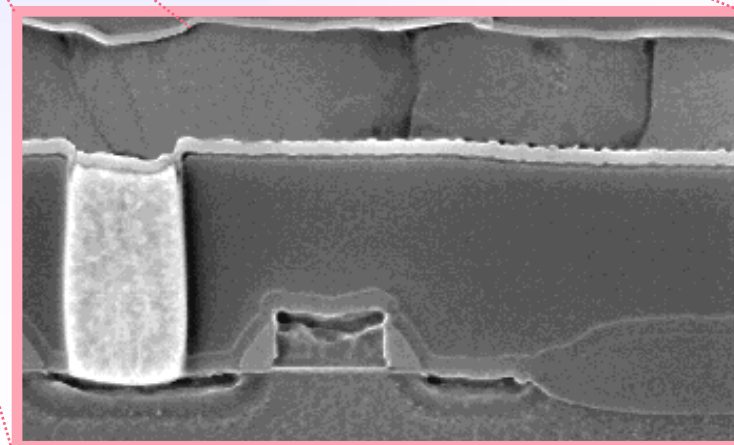
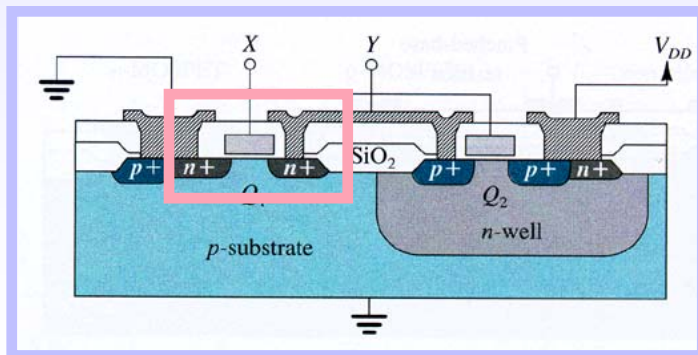
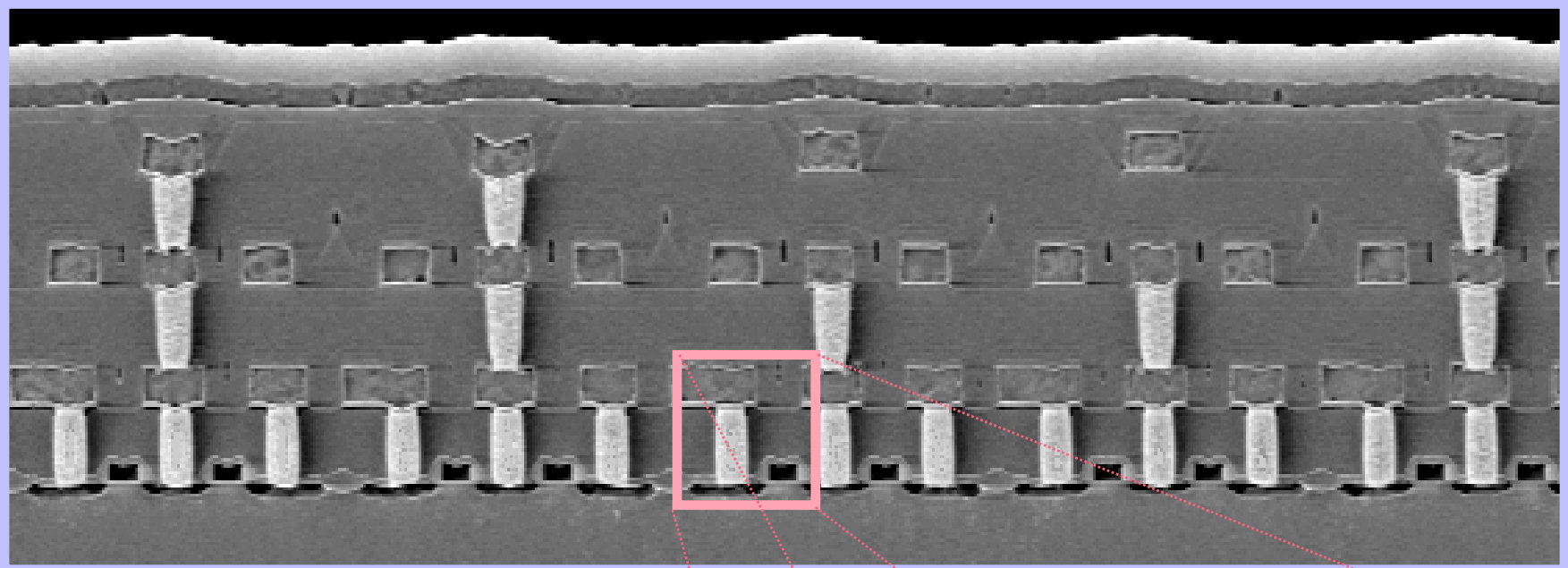

Projeto e Fabricação de CIs

